

## Precision Electronic Components Mfg. Co.

B-51, Electronics Complex, Kushaiguda,  
ECIL PO, Hyderabad, A.P., INDIA 500062.  
(91)-(40) 7120283, 7126228 Fax: (91)-(40) 7126221 E-mail:pecadmin@satyam.net.in



Committed to Quality

### ROTARY SWITCH RS 2/6 TYPE - User's Guide

#### Product Information

In the first of the series of multiposition Rotary Switches, PEC introduces the 2/6 type. 2/6 has two poles with 6 ways. The back plate has two markings A & C for the two poles. The 12 ways are on the outer periphery. The front plate has got 10 slots starting with number 2 for the first slot in the counter clockwise direction.

The 2/6 switch can be used as a 2 / 3 / 4 / 5 way switch by insertion of the notch washer supplied with the switch (with the initial position as the off position) into different slots of front plate. For example, when the notch washer is inserted in the slot no 2 (after the spindle is rotated to its extreme counter clockwise position) and tightened with a nut, the switch will act as a 2 - way switch. As we move the notch washer to the slots 3 / 4 / 5 / 6 Positions, It acts as a 3 / 4 / 5 / 6 way switch where the pole A connects sequentially to 2,3,4,5, and 6 positions and pole C to 7,8,9,10,11 and 12 Positions (Positions 1 & 7 are normally used as off positions.)

#### PCB Mounting Details

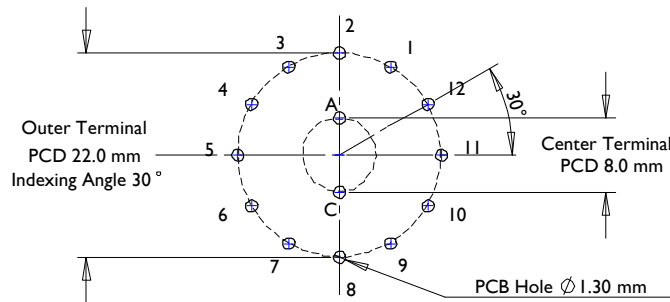

(As Viewed from backside of Rotary Switch / Solder side of PCB)

#### Notch Washer Location and Corresponding Contact Details

The number of switching positions which can be achieved by varying the position of the notch washer in different slots on the mounting face of the Rotary Switch is as indicated in the diagram below (Fig. 2).

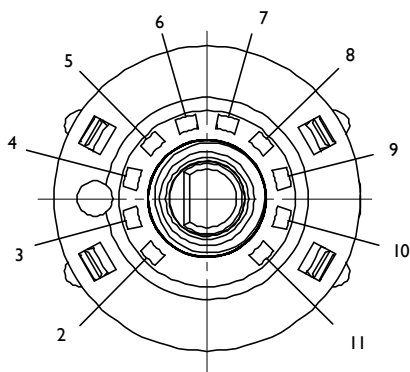

Fig. 2

Notch Washer Position	No. of Switching Positions	Centre Terminal	Shorting Positions of Outer Terminals
2	2	A	1,2
		C	7,8
3	3	A	1,2,3
		C	7,8,9
4	4	A	1,2,3,4
		C	7,8,9,10
5	5	A	1,2,3,4,5
		C	7,8,9,10,11
6	6	A	1,2,3,4,5,6
		C	7,8,9,10,11,12

#### Note:

1. For RS 2/6 (2 pole 6way) Rotary Switches only slot numbers 2,3,4,5 and 6 are applicable.
2. For RS 1/12 (1pole /12way) Rotary Switches all slot positions can be used depending upon switching positions required.(Only centre terminal A is provided which can be shorted to outer terminals 1 to 12)